		2

1.

2 :

3

4

5.

		3

6.

		4

7.

8.

9.

		5

10. mm

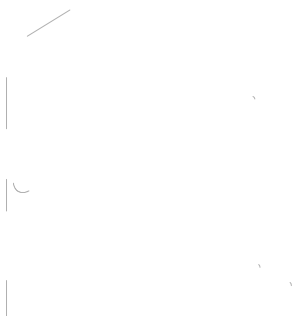
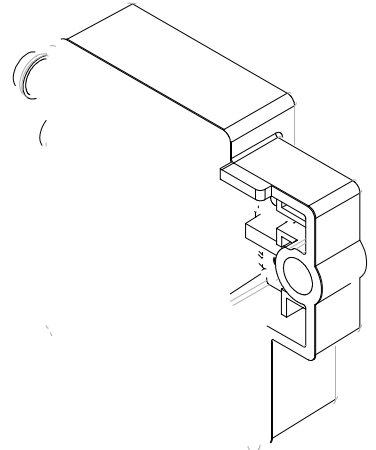
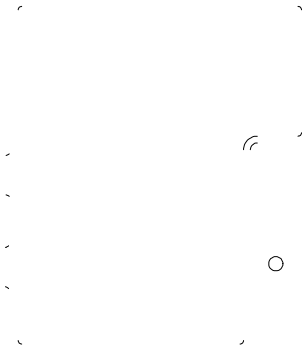
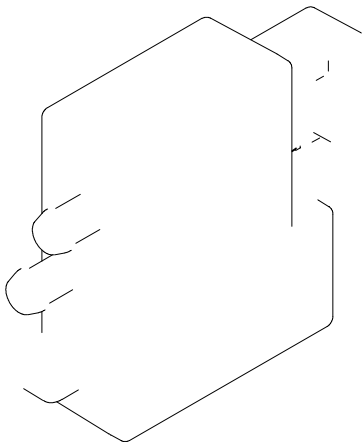

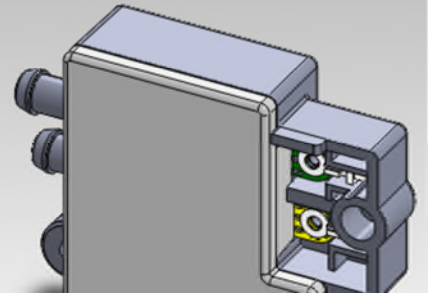
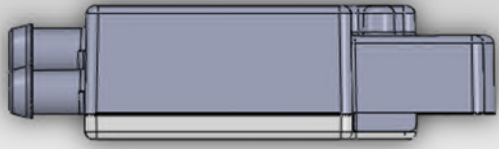

*上视

*上下二等角轴测

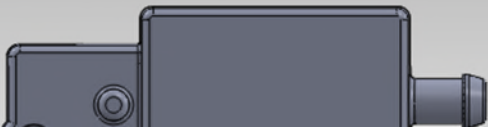
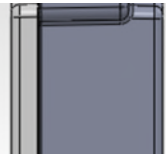

*后视

*左视

